

Model: X2B-1200-6

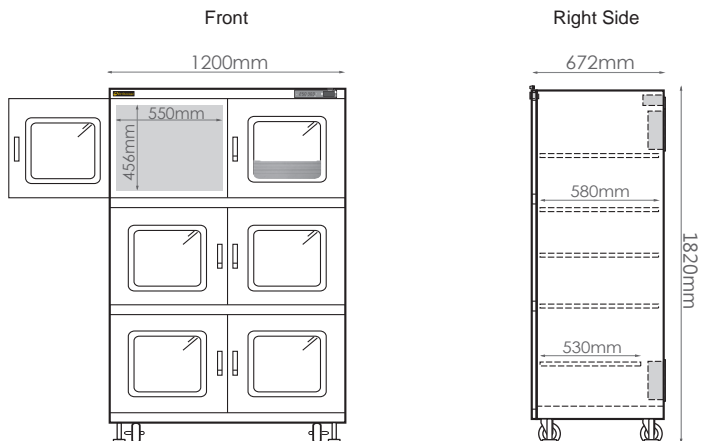

Model: X2B-600

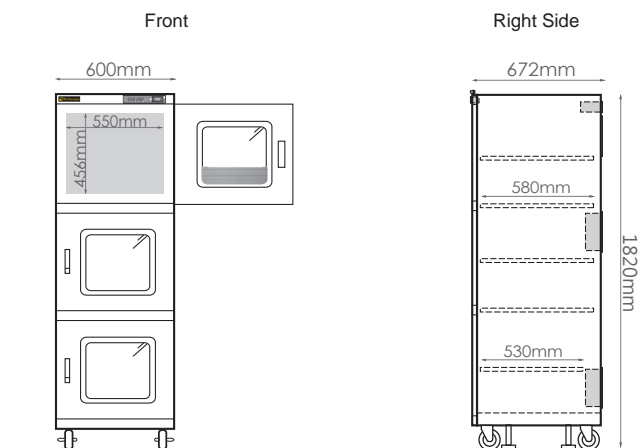

Model: X2B-400

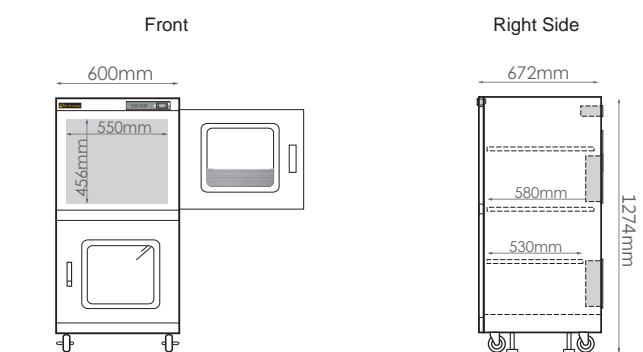

Model: X2B-200

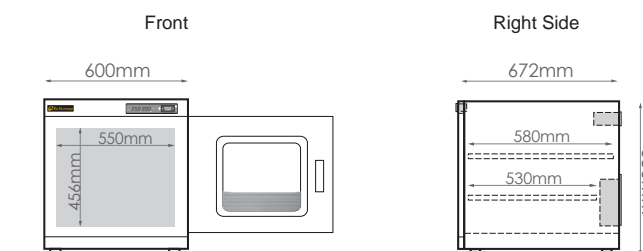

Model: X2B-575

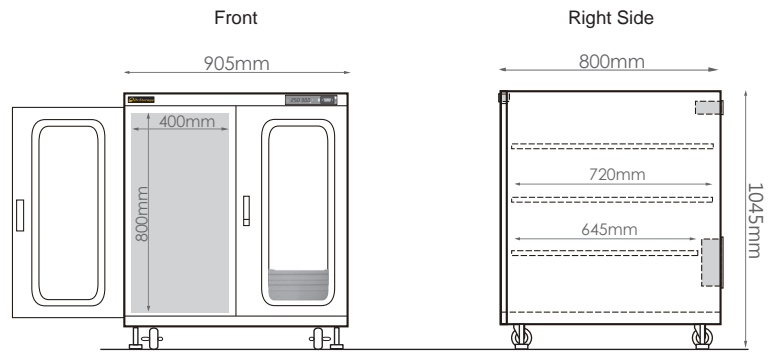

Model: X2B-315

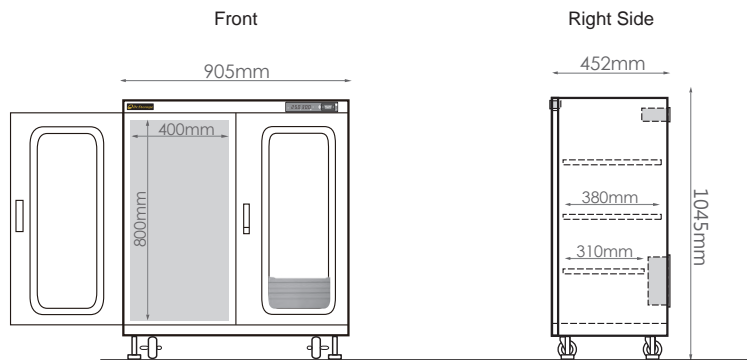

Model: X2B-157

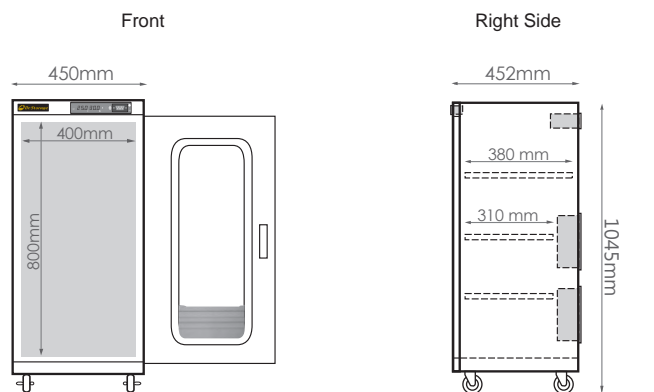

Features



Humidity range : 0.1~5%RH
(Plug and play)



Embedded RS-232 port for a data logger recording and central monitoring system.



Sensor display comes with built-in alarm function.

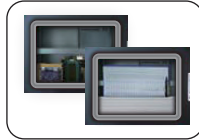

Bins on the windows for color management and document management.



UL and CE approved
Comply with IPC/JEDEC standard for use of moisture/reflow sensitive surface-mount devices.



Calibration reminding function.

Performance

Outstanding Ultra-Low-Humidity Performance

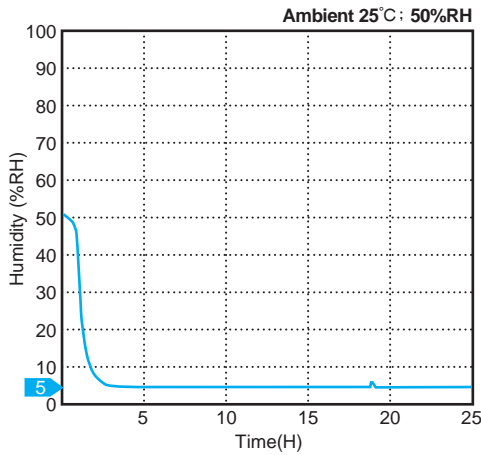

Highly-Efficient Recovery Time

< Door is opened for 30 seconds and closed >

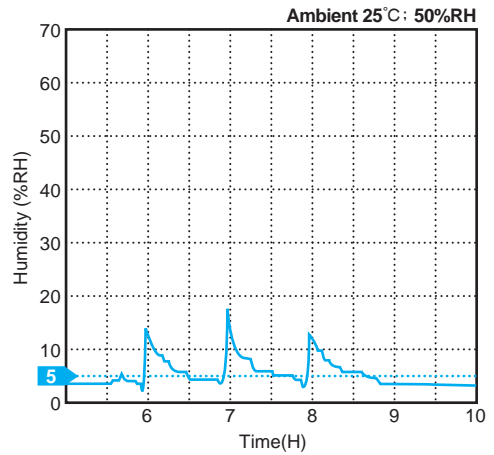

Specifications

Model	X2B-1200-6	X2B-600	X2B-400	X2B-200	X2B-575	X2B-315	X2B-157
External Size W*D*H(mm)	1200*672*1820	600*672*1820	600*672*1274	600*672*636	905*800*1045	905*452*1045	450*452*1045
Internal Size W*D*H(mm)	1164*612*1600	564*630*1600	564*630*1055	564*630*508	869*758*852	869*410*852	414*410*852
Capacity(L)	1250	624	413	202	598	328	164
Adjustable Shelves	4pcs of 1-2 1pc of 1-1	4pcs of 1-4 1pc of 1-3	2pcs of 1-4 1pc of 1-3	1pc of 1-4 1pc of 1-3	2pcs of 1-6 1pc of 1-5	2pcs of 1-8 1pc of 1-7	1pc of 1-10 2pcs of 1-9
Door(s)	6	3	2	1	2	2	1
Sensor Display	Precision : ±3%RH (@25°C · 1~50%RH) , ±1°C / Resolution : 0.1%RH · 0.1°C / Embedded RS-232 port and built-in alarm function						
Cabinet Structure	1mm carbon steel with antistatic black paint / Antistatic glass window(s) and gray window frame. Static dissipative range 10 ⁶ ~10 ⁹ Ω / Grounding wire: 1MΩ(length 1.95M)						
Voltage	110V or 230V (Select in advance)						
Power Consumption	110V : 107Wh(Ave.) 305W(Max.) 230V : 107Wh(Ave.) 345W(Max.)	110V : 55Wh(Ave.) 155W(Max.) 230V : 55Wh(Ave.) 175W(Max.)	110V : 55Wh(Ave.) 155W(Max.) 230V : 55Wh(Ave.) 175W(Max.)	110V : 55Wh(Ave.) 155W(Max.) 230V : 55Wh(Ave.) 175W(Max.)	110V : 55Wh(Ave.) 155W(Max.) 230V : 55Wh(Ave.) 175W(Max.)	110V : 55Wh(Ave.) 155W(Max.) 230V : 55Wh(Ave.) 175W(Max.)	110V : 55Wh(Ave.) 155W(Max.) 230V : 55Wh(Ave.) 175W(Max.)

The best performance is achieved under the ambient condition below 25°C and 50%RH

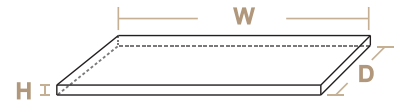

Item	①
Item Name	Shelf
Picture	

Item	Model	Size
① - 1	1200-6	W1155*D530*H20mm
① - 2	1200-6	W1155*D580*H20mm
① - 3	600/400/200	W555*D530*H20mm
① - 4	600/400/200	W555*D580*H20mm
① - 5	575	W860*D645*H20mm
① - 6	575	W860*D720*H20mm
① - 7	315	W860*D310*H20mm
① - 8	315	W860*D380*H20mm
① - 9	157	W405*D310*H20mm
① - 10	157	W405*D380*H20mm

Item	②
Item Name	Stainless Steel Shelf
Picture	

Item	Model	Size
② - 1	1200-6	W1155*D530*H20mm
② - 2	1200-6	W1155*D580*H20mm
② - 3	600/400/200	W555*D530*H20mm
② - 4	600/400/200	W555*D580*H20mm

Item	③	④	⑤	⑥
Item Name	GT-05 Data Logger	External Alarm Tower	QDN	Flow Meter
Description	Memory capacity 40,000 records.	When the Rh exceeds the preset value, it will flash and buzz (100-120 dB).	The nitrogen will stop as soon as the relative humidity reaches preset value. Inlet dia. : \varnothing 8mm	Spec:10-60L/min Inlet dia. : \varnothing 8mm
Picture				

Item	⑦	
Item Name	Storage Bin	
Description	Max Load Weight : 5kg External Size : W395*D40*H98mm Internal Size : W365*D30*H90mm	Max Load Weight : 5kg External Size : W237*D40*H98mm Internal Size : W210*D28*H87mm
Picture	<p>Available for X2B-1200-6/600/400/200</p>	<p>Available for X2B-575/315/157</p>