

# JBC

[www.jbctools.com](http://www.jbctools.com)

## INSTRUCTION MANUAL

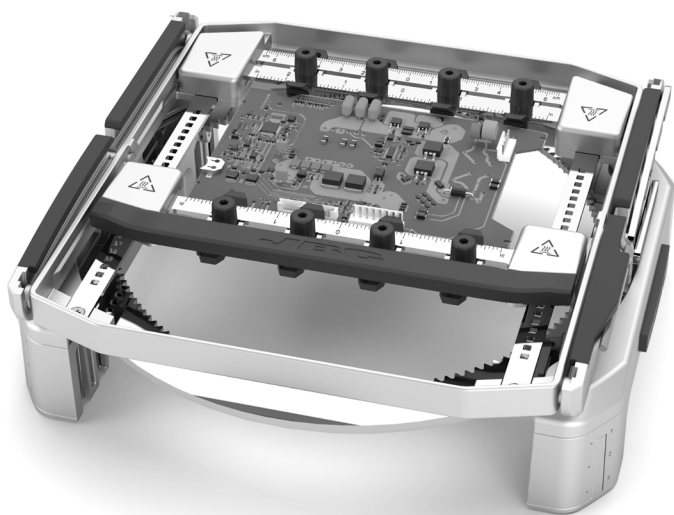

### PSS

Multiaxis Rotative PCB Support

This manual corresponds to the following reference:

PSS-A

## Packing List

The following items are included:

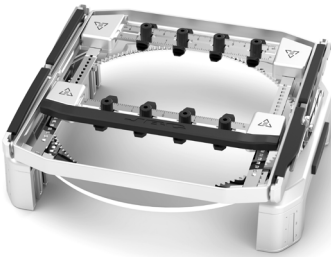

Rotative Support ..... 1 unit

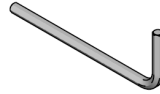

Allen Key ..... 1 unit  
Ref. 0032547



Manual ..... 1 unit  
Ref. 0032070

## Application

PSS is designed to support and fix PCBs to perform soldering and desoldering jobs with or without preheaters. JBC's rotary support can work with JBC's PHSE Preheater.



**Caution:** Take care when working with preheaters since metal surfaces of the support can be hot - especially the sliding guide and the spring guide.



**Features - Horizontal Position**

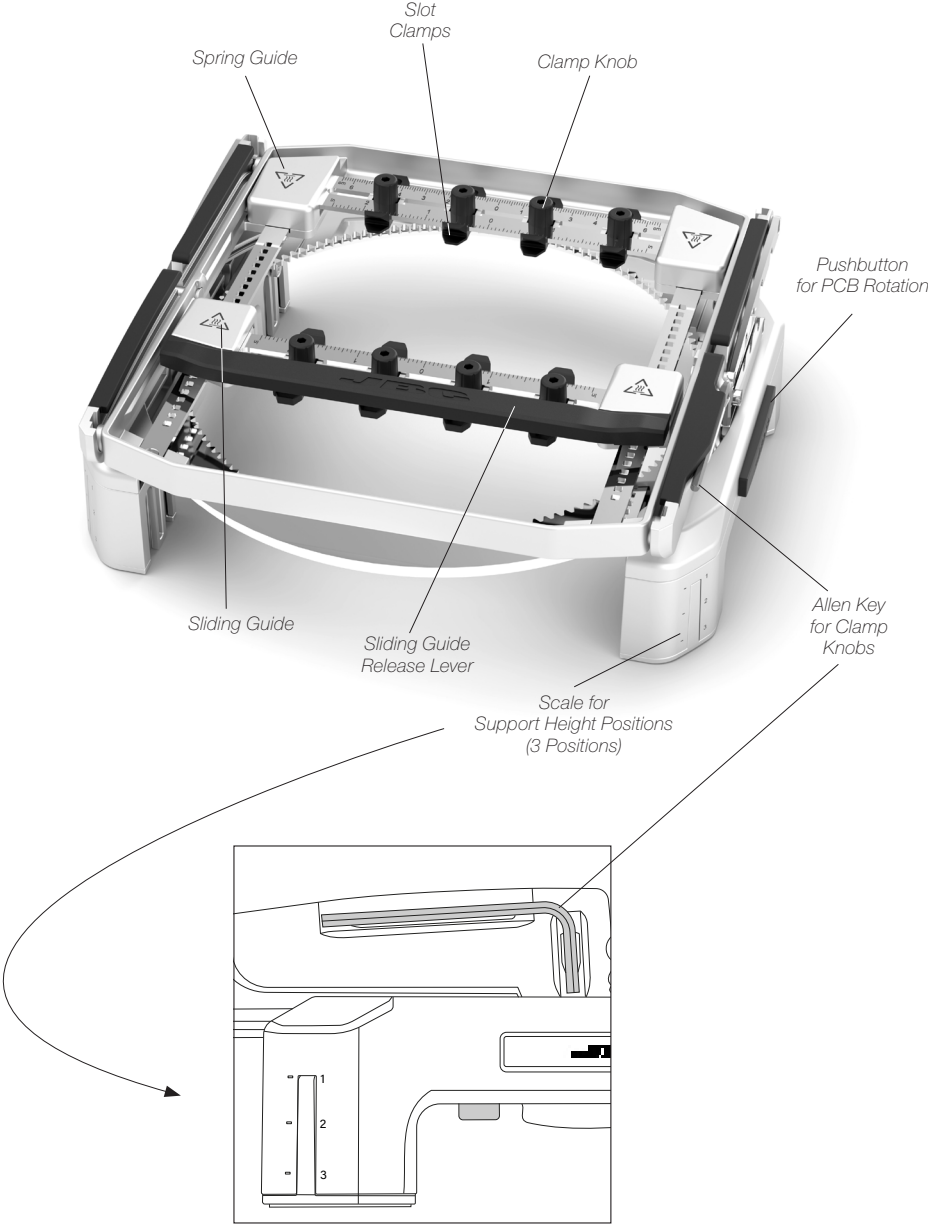

# Features - Inclined and Rotated Position

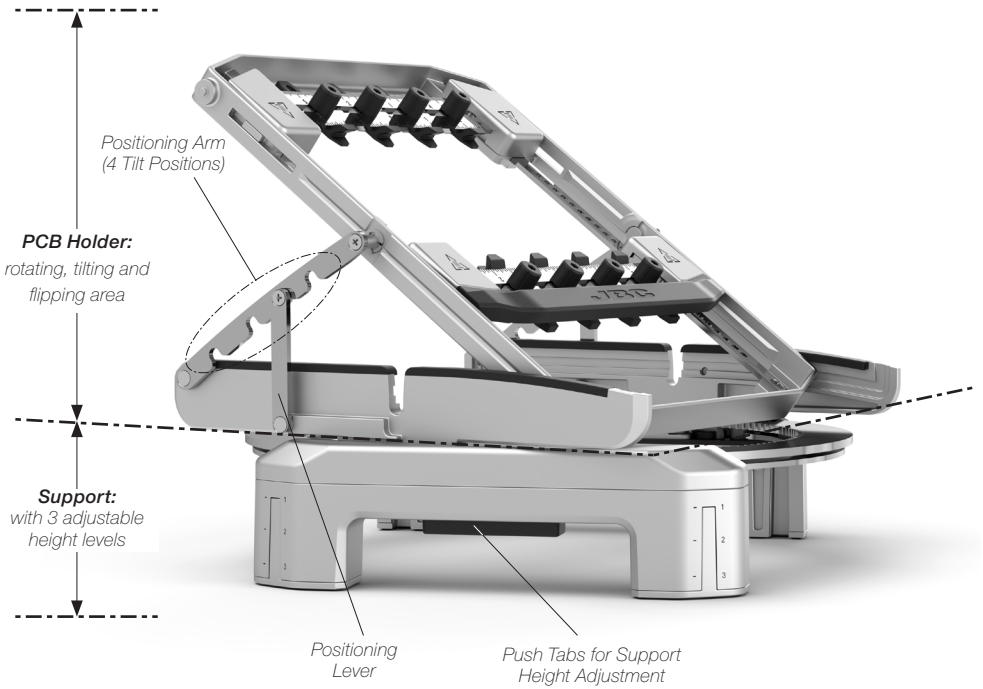

# ESD Connections

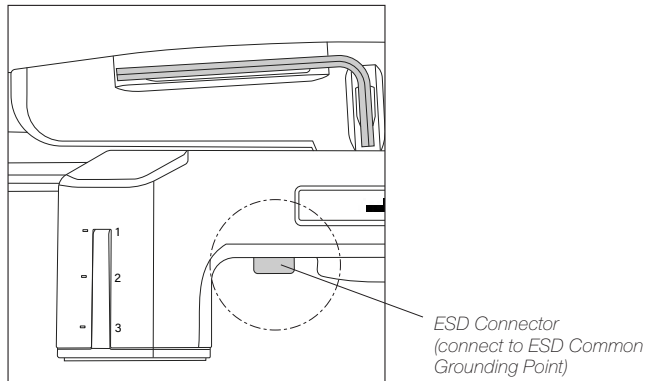

## Height Adjustment

The support incorporates a height adjustment mechanism inside the support legs. Choose between 3 different height levels.

### Level 1

Without support elevation

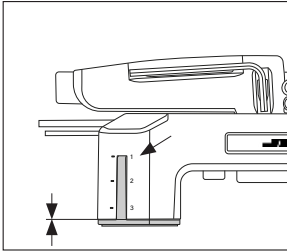

### Level 2

Support elevation  
10 mm / 0.04 in

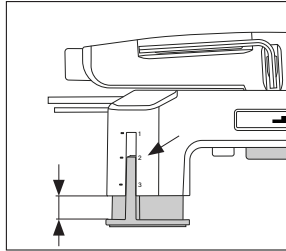

### Level 3

Support elevation  
22.5 mm / 0.89 in

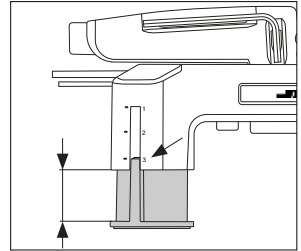

To adjust the height, press the two lower push tabs upward at the same time and hold them pressed (1).

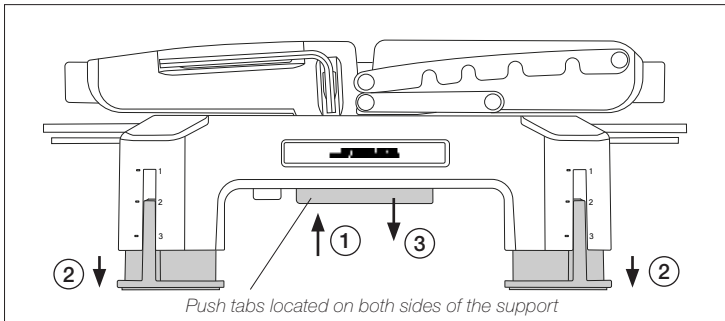

Lift the support while holding the tabs and let its feet drop down under their own weight (2).

While continuing to hold the lower tabs, place the support on the workplace and lower it until it reaches the desired height.

Release the tabs and the legs will automatically lock into position (3).

**Note:** Make sure that the components already mounted on the PCB do not come too close to the preheater plate.

If components are too close to the heating surface, they may be damaged. To avoid this, set the support height to level 2 or level 3 or set an adequate PCB holder angle to ensure sufficient distance.

Pay special attention when turning the PCB holder upside down.

# PCB Holder Positions

## Default Position

(Level 1 - without elevation)

By default, the sliding guide release lever is located at the front and the push button for holder rotation on the right side.



## Rotated Position

(360° range)

To rotate the PCB holder, press the lateral push button (1) to unlock its position. While the button is pressed, the holder can be rotated to the desired position (2). **Note:** In order to be able to rotate freely, the support needs to have a free space of at least 30 cm in diameter.

Release the lateral push button and the holder will rest in the desired position.

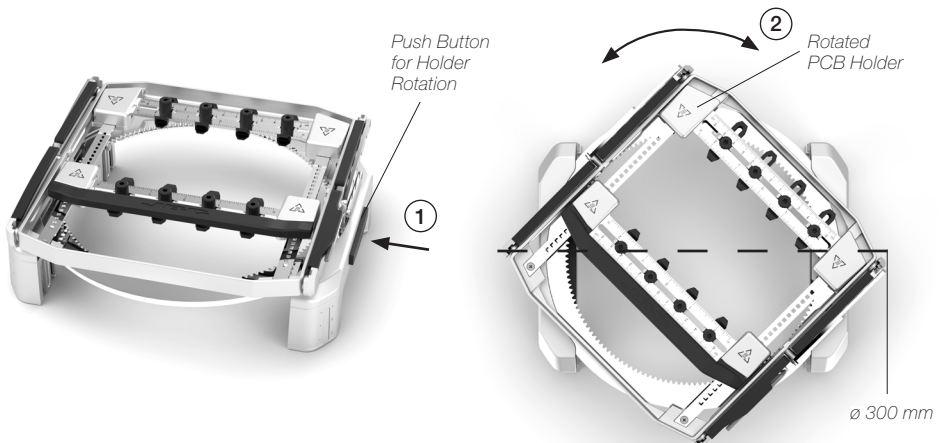

## Inclined Position

To place the holder in an inclined position, lift the rear end slightly upwards and hold the holder in the desired angular position (1).

With the other hand, turn the positioning lever upwards (2) and insert its stud into one of the openings of the positioning arm (3). Do the same on the opposite side to completely fix the holder in the desired position.

It is possible to choose between 4 different angular positions: 25°, 35°, 45° and 55°. **Note:** When working at 55° and level 3 height, the total height of PSS reaches 24.5 cm (up to 30 cm at 90°).

To return the holder to the horizontal position, set the lever to its horizontal position (4) - for a holder angle of 0°.

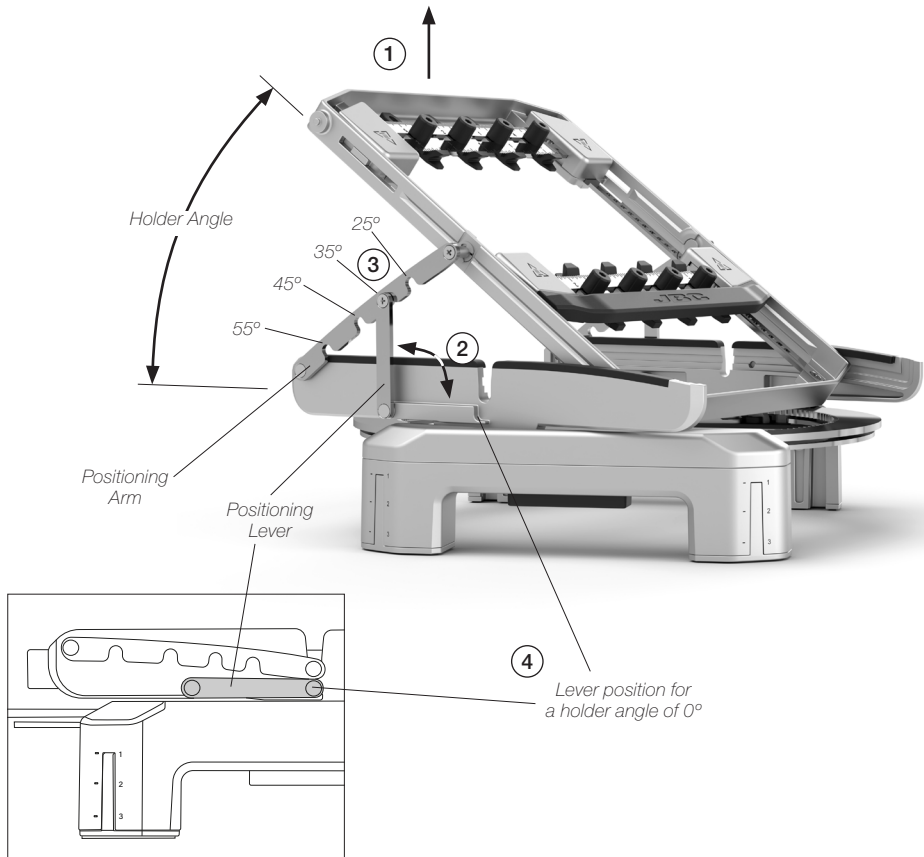

**Caution:** When adjusting and changing the support positions, be aware that the metal surfaces may be hot.

## Upside Down Position

(180° - inverted position)

The PCB holder can be turned upside-down (180°), this means the top side of the PCB then faces downwards.

This has the advantage that the PCB does not have to be repositioned if soldering is to be carried out on the top and on the bottom side of the PCB.

**Note:** Be aware that after turning it around, larger components may come too close to the preheater heating surface or table. If necessary, set a different support height (see chapter “Height Adjustment” on page 5).

## Horizontal Upside Down Position

If the holder is in a **horizontal position**, proceed as follows to **turn it upside down**:

Grasp the holder at the front (1) and slide it upwards until it is in a vertical position (2).

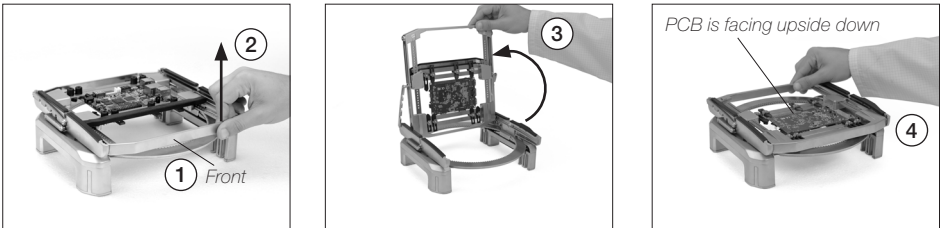

Then tilt the holder all the way back (3) until it comes to rest in a horizontal position again (4).

The holder is now completely turned around by 180° and the top side of the PCB is facing down.

Proceed in reverse order if you want to work on the top side of the PCB again.

## Angular Upside Down Position

If the holder is in an **inclined position**, proceed as follows to turn it **upside down**:

Grasp the holder at the top and slide it upwards (1). Both position levers will automatically drop down to their horizontal position (2) and will release the previous holder position.

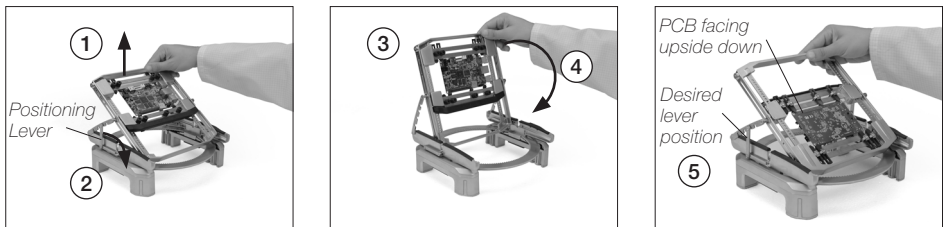

Keep lifting the holder until it is in a vertical position (3).

Then tilt the holder all the way to the desired angular position (4) and insert the studs of the positioning levers in the desired position to fix the holder in place (5).

The PCB is now turned around by 180° and the top side of the PCB is facing down.

Proceed in reverse order if you want to work on the top side of the PCB again.

## PCB Placement

Loosen the knobs of the spring guide clamps (1), adjust their distance according to the PCB width (2) and tighten the knobs again. Clamps that are not needed can be slid to the side (3) (or disassembled).

Loosen the knobs of the sliding guide clamps (4) and slide unneeded clamps aside (5).

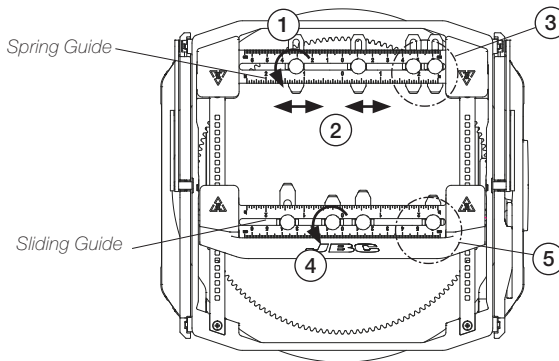

Insert the PCB into the slots of the spring guide clamps (6) and into at least one slot clamp on the side of the sliding guide (7) and tighten the clamp knob (8).

Press the sliding guide against the PCB to move it together with the spring guide slightly backwards (9) until the sliding guide clicks into place.

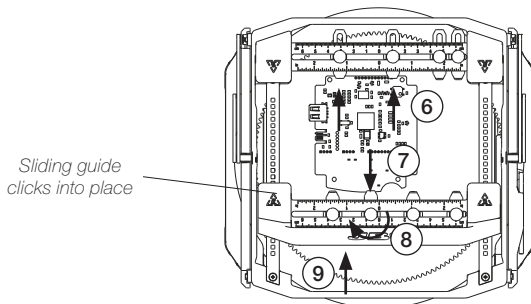

Now adjust the positions of the other required slot clamps to the PCB shape and tighten their clamp knobs (10) after the adjustment.

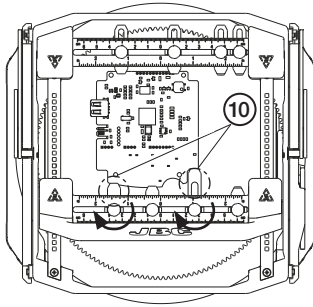

The clamp knobs can be loosened and tightened by hand and/or by means of the provided Allen key.

The Allen key is stored on the side of the support and held in place by a built-in magnet.

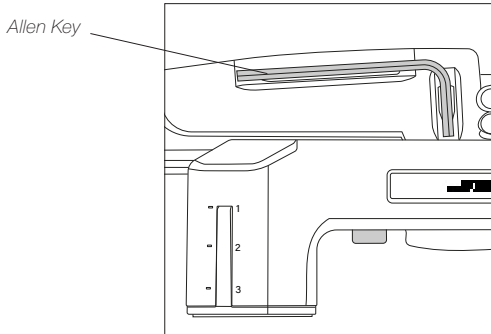

**Note:** The spring guide is not adjustable, but is spring loaded, which allows to change PCBs quickly. See next chapter “Fast PCB Replacement”.

## Fast PCB Replacement

### Removing the PCB

Push the PCB against the spring guide (1) until it moves back slightly.

Now the PCB can be taken out of the clamps at the front (2).

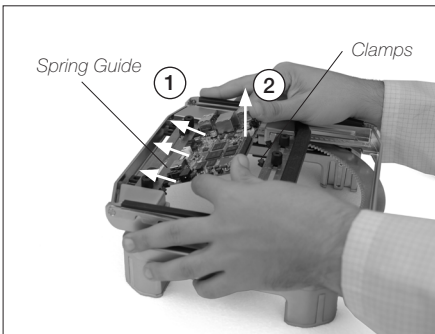

### Placing another PCB

Position a new PCB inside the slot clamps of the spring guide. Push it backwards (against the spring force) until it moves slightly backwards (3).

Rotate the free side of the PCB downward and position it in the slot clamps of the front area (4).

The spring guide automatically locks the PCB into position.

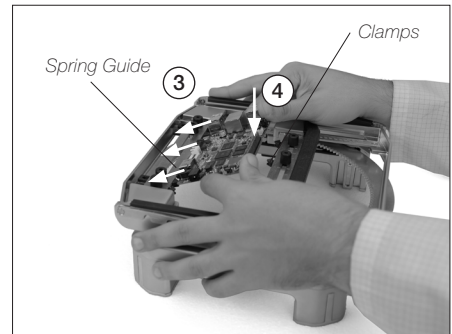

## Maintenance

Before carrying out maintenance or storage, always allow the support to cool down.

- Check periodically that the Support is clean, especially the axes of the sliding guide.
- Use a damp cloth when cleaning. Alcohol can only be used to clean the metal parts
- Replace any defective or damaged piece. Use original JBC spare parts only.
- Repairs should only be performed by a JBC authorized technical service.



## Safety



**It is imperative to follow safety guidelines to prevent electric shock, injury, fire or explosion.**

- When using the support with a preheater unit, the temperature of accessible surfaces may remain high after the unit is turned off. Handle with care.
- Be careful with the remains of liquid tin. In contact with the skin, it can cause burns.
- Avoid flux coming into contact with skin or eyes to prevent irritation.
- Be careful with the smoke produced when soldering.
- Keep your workplace clean and tidy. Wear appropriate protection glasses and gloves when working to avoid personal harm.
- This appliance can be used by children over the age of eight as well as persons with reduced physical, sensory or mental capabilities or lacking experience provided that they have been given adequate supervision or instruction concerning the use of the appliance and understand the hazards involved. Children must not play with the appliance.
- Maintenance must not be carried out by children unless supervised.







# Specifications

## PSS

### Multiaxis Rotative PCB Support

Ref. **PSS-A**

- |  |  |
|--|--|
| - Support Dimensions (Low Position):<br>(L x W x H)  | 235 x 245 x 80 mm<br>9.25 x 9.65 x 3.15 in                       |
| - Support Dimensions (High Position):<br>(L x W x H) | 235 x 245 x 105 mm<br>9.25 x 9.65 x 4.13 in                      |
| - Support Max. Diameter (Rotated Position):          | 300 mm / 11.81 in  |
| - Support Max. Height (Flip):                        | 300 mm / 11.81 in  |
| - Max. PCB Dimensions (Between Clamps):              | 13 x 13 cm / 5 x 5 in<br>Thickness 6 mm / 0.236 in               |
| <br>   |  |
| - Total Net Weight:                                  | 2.464 kg / 5.43 lb   |
| - Total Package Dimensions / Weight:<br>(L x W x H)  | 280 x 280 x 164 mm / 2.95 kg<br>11.02 x 11.02 x 6.49 in / 6.5 lb |

Complies with CE standards.  
ESD safe.

# JBC

## Warranty

JBC's 2 year warranty covers this equipment against all manufacturing defects, including the replacement of defective parts and labour.

Warranty does not cover product wear or misuse.

In order for the warranty to be valid, equipment must be returned, postage paid, to the dealer where it was purchased.



This product should not be thrown in the garbage.

In accordance with the European directive 2012/19/EU, electronic equipment at the end of its life must be collected and returned to an authorized recycling facility.



[www.jbctools.com](http://www.jbctools.com)