

JBC

www.jbctools.com

INSTRUCTION MANUAL



B·NANO

Nano Handle for B·IRON

This manual corresponds to the following reference:

BN-A

Packing List

The following items are included:



B-NANO
Nano Handle for B-IRON 1 unit



B1510
Grips for B-IRON Handles 1 unit
Ref. B1510



Grip Fitters 2 units



OB5000
Sealing Plug for B-NANO Handle 1 unit
Ref. OB5000

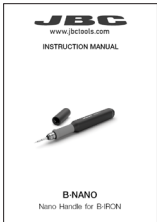

Manual 1 unit
Ref. 0033729

 Please read this manual and its safety guidelines thoroughly before using the product.

Features

B-NANO performs up to 120 SMD soldering joints per charge and is the ideal tool for applications in laboratories or performing individual soldering jobs that require the highest precision.

Note: To charge the tool a B-IRON station is needed.

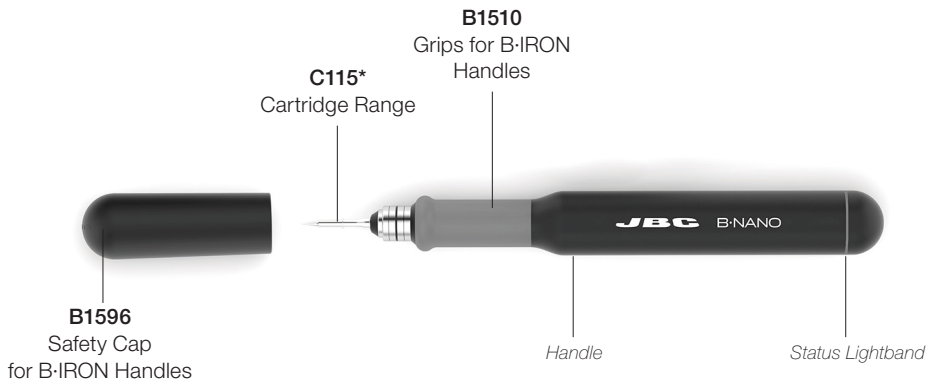

Compatible Cartridges*

B-NANO works with C115 Cartridges. Find the model that best suits your soldering needs on www.jbctools.com.

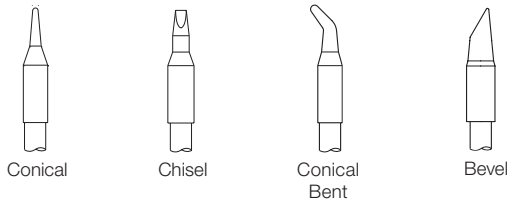

* Not included, sold separately.

Connection with B-IRON Station

PDS *
Portable Display 7"
for B-IRON

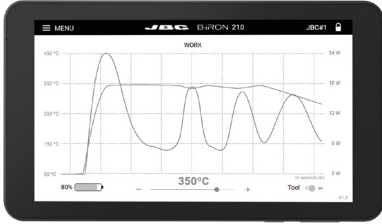

Bluetooth
Connection



USB Cable *



USB Connector

Power Socket



B-NANO
Nano Handle
for B-IRON



C115
Cartridge
Range



B1596
Safety Cap
for B-IRON Handles



* Not included, sold separately.

Cartridge Insertion and Charging

Inserting

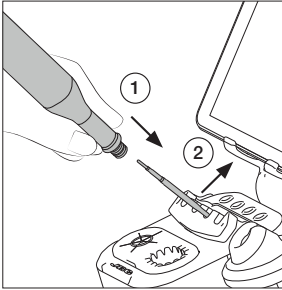

Place the tool over a cartridge and press the tool down to insert the cartridge (1). To release the tool with the cartridge from the extractor, lift the tool upward (2).

Fixing

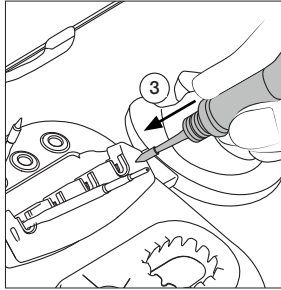

Make sure that the cartridge is appropriately inserted* into the tool by gently pressing the tip against the holes on the sides of the cartridge exchanger.

Note: Cartridges must be inserted up to the reference ring for a proper connection.



Charging

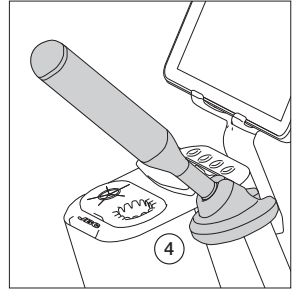

Place the tool in the charging holder (4) to charge it. A beep will sound to confirm that the tool is properly placed and charging. The sound can be turned up, down or off using the left button on the display.

! Note: Charge the tool completely before using it for the first time. A full charge takes:
-30 min for B-100
-60 min for B-500
-30 min for B-NANO

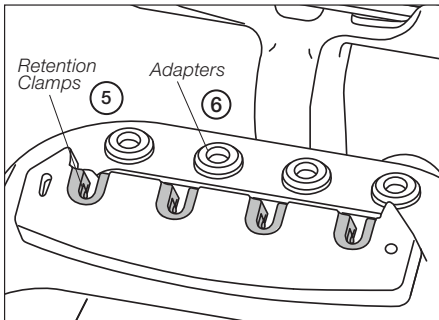

Cartridge Retention

Cartridges are held in place inside the cartridge exchanger thanks to the retention clamps (5), with the advantage that the cartridges do not fall into the exchanger and the cartridge tips are therefore protected.

The cartridge exchanger of B-IRON stations works with C210 and C115 Cartridges.

C115 Cartridge Adapters

C115 Cartridges cannot be stored inside the cartridge holder slots by themselves. It is necessary to insert B0643 C115 Cartridge Adapters into the slots (6) so that the cartridges don't sink all the way in.

C115 Cartridge Retention Area

The holding area of C115 Cartridges is delimited by the two rings at the cartridge shaft (x).

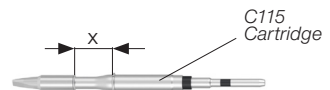

Tool Connection

Make sure that the charging base is connected to the mains.

Note: The supplied tool is already connected.

Scanning another tool: *(This process can take a while)*
Place the tool in the charging holder to activate it. The status light band color indicates the charge level (see table below).

If the scanning process does not run automatically, tap “scan” (6) on the display while the tool remains in the charging holder. When the tool is shown in the device list on the display, select it (11) and tap “connect” (7). Now the tool is ready for soldering.

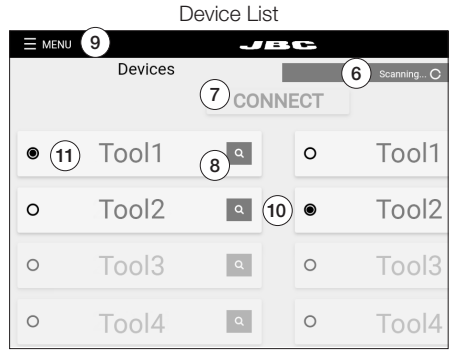

Tool search function:

When in doubt of which tool corresponds to the tool’s name, use the tool search function. Tap on the magnifying glass symbol (8) next to the tool’s name. The light band on the corresponding tool blinks in blue for five seconds to identify it.

Working with two tools *(works also for charging bases with only one charging holder):*

It is possible to connect up to two tools at the same time. If a tool is already connected, first disconnect it from the device by selecting “Menu” (9) and tapping on “Disconnect”.

Place the second tool in the charging holder and scan it (6). The second tool is also shown in the device list on the display (10). To work with two tools, select one from the left-hand column (11) and the other one from the right-hand column (10). Then tap on “connect” (7).

Status Lightband

The status lightband on the tool indicates its status (see table on the right).



Color	Tool Status
Green	More than 50% charged
Orange	Between 20% and 50% charged
Red	Less than 20% charged
Green blinking	Charging (more than 50% charged)
Orange blinking	Charging (between 20% and 50% charged)
Red blinking	Charging (less than 20% charged)
No color	Safety cap on the handle and/or power off
Blue blinking	Locate Tool function activated

Safety Cap

Thanks to their safety cap, B-IRON handles can be transported safely, even with the cartridge inserted.

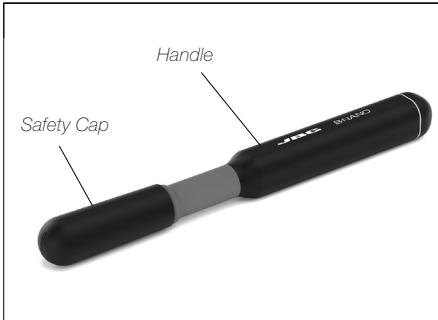

When the cap is placed onto the handle, the cartridge stops heating, data transfer is cut off and the handle is disconnected from the station.

If the cap is removed before 60 minutes, the tool reconnects and heats up immediately. After 60 minutes with the cap on and without any movement, the handle turns off completely and it is necessary to reactivate it:



To reactivate and turn on the handle, the cap must be removed and the handle inserted in the charging holder so that the station recognizes the handle.

Important: After use, it is recommended to leave the tool in the charging holder until the next use so that it is ready and fully charged. The function of the cap is to allow safe transport, not storage.

Safety Cap Holder

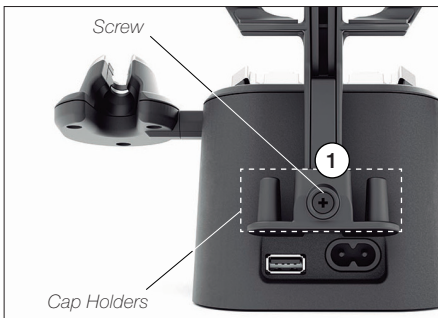

While the handle is in use, the cap can be stored on the cap holder located on the back of the charging base. There is space for two caps.

If desired, the cap holder can be detached by removing the screw (1).

Operation

JBC's Most Efficient Soldering System

This revolutionary technology recovers tip temperature extremely quickly. This allows the user to work at a lower temperature and therefore cartridge tips last longer.

Work

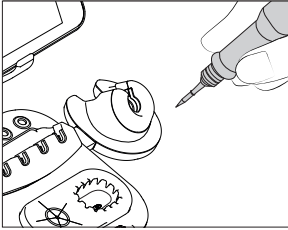

When the tool is lifted from the tool holder, the tip of the assembled cartridge heats up to the selected working temperature.

Charge Mode

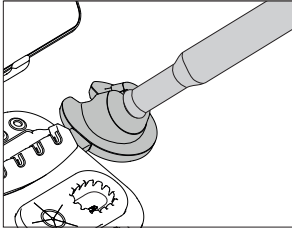

While the tool remains in the tool holder, it charges and the tip gradually cools down to room temperature.

Sleep Mode

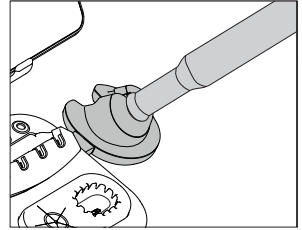

If Sleep Mode is activated (see section "Settings"), upon placing the tool in its holder, besides charging it enters Sleep Mode. The tip temperature drops down and remains at Sleep temperature.

Hibernation Mode

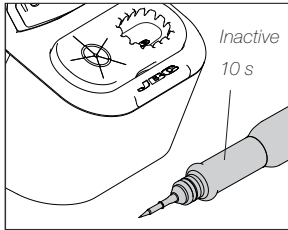

When the tool is away from the tool holder and remains inactive (no movement for at least 10 seconds), it goes into Hibernation Mode and the tip temperature gradually cools down to room temperature.

Automatic Turn Off

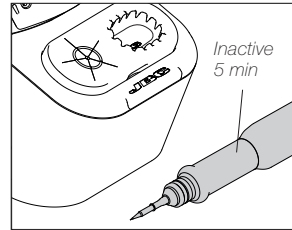

If the tool has been inactive for a longer period of time (at least 5 minutes), it automatically turns off.

Turning the Tool Back On

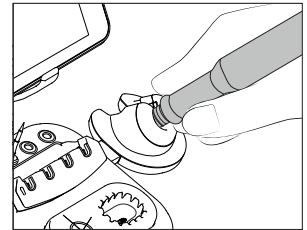

After automatically turning off, put the tool back in the holder to turn it on again.

Note: The tool can also be switched off/on manually. Tap the *Tool* power switch on the display (bottom right) to switch it off/on (if the tool is turned off, it will remain connected up to 5 minutes to the station but will not heat up the cartridge).

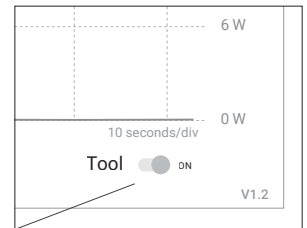

Tool Power Switch

Replacing B1510 Grips *(Soft Foam)*

Inserting Fitters

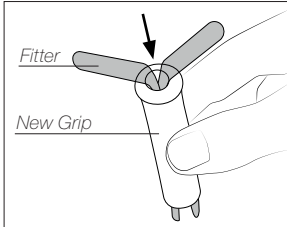

Insert the fitters into the new grip.

Assembling Grips

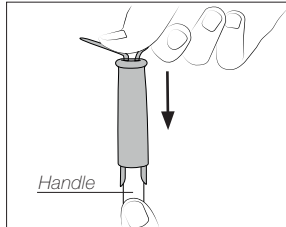

Push the grip with the fitters onto the handle.

Removing Fitters

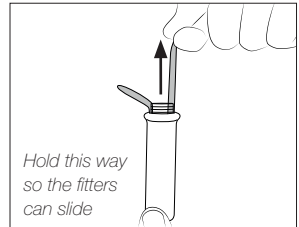

To remove the fitters, hold the grip and pull the fitters out. Use pliers if necessary.

Replacing Sealing Plugs

The sealing plug prevents undesirable flux vapors or particles from entering the handle. Its usage is highly recommended for intensive applications when soldering is exposed to FOD environments or for applications where the soldering iron works close to a vertical position.

Note: Choose between the two available sealing plug references depending on your handle model.

⚠ Before replacing the sealing plug, disconnect the handle from the station and make sure the device is not hot.

Handle	Sealing Plug
B-100	OB4000
B-500	
B-NANO	OB5000

OB5000 for B-NANO Handles

⚠ For B115 handles, the use of the OB5000 sealing plug is mandatory.

Without the use of the sealing plug, the cartridges cannot be properly inserted.

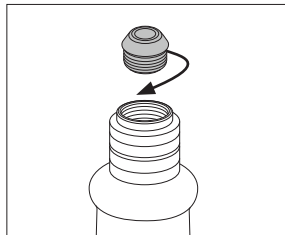

OB5000 has a thread for attaching the plug to the handle.

To replace it, unscrew the plug, replace it with a new one and screw it in until fixed.

JBC Software

The app is already installed on JBC's B-IRON Display. If another display is to be used, the app must be downloaded to the corresponding display (see chapters below).

At the moment of purchasing the B-IRON tool, the current firmware is already downloaded to the tool.

Note: Since the tool firmware is not updated automatically, updates must be carried out by the customer. To do so follow the instructions on the next page.

App Versions

If an app with version 1.6 or higher is already installed on the display (tablet or smartphone) used with B-IRON, the firmware of the tool can be updated directly without updating the app. Carry out the steps described in section "B-IRON Tool Firmware Update".

Older app versions must be updated. If no app has been installed, it must be installed first.

App Installation

On **JBC's portable display** (*Android*), the B-IRON app is already installed.

On the **user's smartphone or tablet** (*Android / iOS*), go to the App Store/Play Store and search for "JBC B.IRON" on the search bar. **Note:** Internet connection is required to download the app.

Alternatively, scan these QR codes to access the B-IRON app page directly:



The image shows two QR codes side-by-side. The left one is for the App Store, with the text "Download on the App Store" above it. The right one is for Google Play, with the text "ANDROID APP ON Google play" above it.

App Update

Display with internet connection (*Android / iOS*)

Update the app using Google Play (*Android*) or the App Store (*iOS*).

Display without internet connection (*Android*)

Download JBC's installer program to another device with an internet connection from JBC's website: <https://www.jbc tools.com/jbcsoftware.html>



Then copy the downloaded program to the internal storage of the display used with B-IRON. Access the internal storage of the display and run the downloaded program. Once the program is completed, the app will be updated to its newest version.

Note: For JBC's displays, swipe down to open the internal storage folder.

Downloading the Tool Firmware Update File

Display with internet connection:

Download the firmware update file to the display used with B-IRON from: <https://www.jbctools.com/jbcsoftware.html>. Go to the internal folder and unzip the downloaded file.

Display without internet connection:

Download the firmware update file to another device with an internet connection from JBC's website: <https://www.jbctools.com/jbcsoftware.html> and unzip the downloaded file.

Then do as described in the table.

PDS JBC's display (android)	Other android devices	iOS devices
Copy the unzipped files on the device used with B-IRON:		
Folder:	Folder:	Path:
\Internal shared storage\Android\data\es.infinitysource.jbc_soldering.JBCBiron\files	\Internal shared storage\Android\data\com.jbctools.jbcbiron\files	Files > On my iPad > JBC B.iron 

Executing the Tool Firmware Update File

Tool firmware updates are not executed automatically; they must be carried out by the user.

On the display you are using with the B-IRON, and the latest app version installed, access the B-IRON app:



Select the tool you want to update. Then in the main menu select "update".

Note: At least one tool must be linked to see the expanded menu options.

Main Menu with expanded menu options

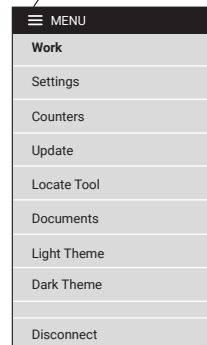

Executing the Tool Firmware Update File *(continuation)*

If the downloaded tool firmware update file contains a newer version than the one already installed, the current and new version are displayed (1). Tap “Update” to start the update (2).

The update process takes about 10 minutes.

The B-IRON status light continuously changes its colour during the update process.

Once the update is completed, “Tool updated” (3) will be displayed.

If “No new version available” is displayed (4), no update is possible nor required.

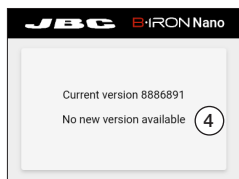
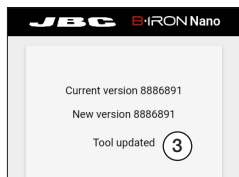
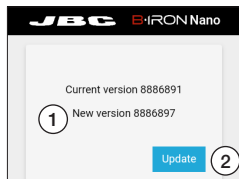

Maintenance

Before carrying out maintenance, always extract the cartridge from the tool and disconnect the charging stand from the mains. Allow the equipment to cool down.

- Use a damp cloth to clean the casing and the tool. Alcohol can only be used to clean the metal parts.
- Periodically check that the metal parts of the tool and tool charger are clean so that the charging works properly.
- Keep the tip surface clean and tinned prior to storage in order to avoid tip oxidation. Rusty and dirty surfaces reduce heat transfer to the solder joint.
- Do not use liquids such as alcohol, thinner or benzene to clean the tablet.
- Repairs should only be performed by a JBC authorized technical service.

Clean the contact surfaces regularly to ensure that the tool gets charged correctly



Safety - Battery



It is imperative to follow safety guidelines to prevent electric shock, injury, fire or explosion.

- **Caution:** This product contains lithium-ion batteries. Mishandling or improper use may result in fire, explosion, or personal injury.
- Always use the provided charger. Do not use damaged chargers or batteries.
- Never attempt to disassemble or modify the batteries or the product. Doing so may lead to electric shock, fire, or damage to the product.
- In the event of damage, leakage, or overheating of the batteries, discontinue use immediately and contact customer support or JBC technical service facility.
- Dispose of devices with batteries inside, responsibly according to regulations. They must be disposed of in accordance with local regulations so that they can be recycled.
- Do not throw devices with batteries into household waste and do not dispose of them in fire or water.

Safety



It is imperative to follow safety guidelines to prevent electric shock, injury, fire or explosion.

- Do not use the units for any purpose other than soldering or rework. Incorrect use may cause a fire.
- The power cord must be plugged into approved bases. When unplugging it, hold the plug, not the wire.
- Do not attempt to dismantle or open the housing of the tool as it may cause damage.
- Do not work on electrically live parts.
- The tool should be placed in the charging holder when not in use in order to charge the batteries.
- The soldering tip, the metal part of the tool and the charging holder may still be hot even when the station is turned off.
- Do not leave the tool unattended when it is on.
- Avoid flux coming into contact with skin or eyes to prevent irritation.
- Be careful with the fumes produced when soldering.
- Keep your workplace clean and tidy. Wear appropriate protection glasses and gloves when working to avoid personal harm.
- Utmost care must be taken with liquid tin waste, which can cause burns.
- This appliance can be used by children over the age of eight and also persons with reduced physical, sensory or mental capabilities or lack of experience provided that they have been given adequate supervision or instruction concerning the use of the appliance and understand the hazards involved. Children must not play with the appliance.
- Maintenance must not be carried out by children unless supervised.
- Do not expose the portable display to high temperatures, humidity or dust. Avoid direct sunlight.
- Do not drop the portable display or the tool, as it may cause damage or malfunction.
- Do not disconnect your device when it is in file transfer mode.
- Do not use the portable display in places where wireless communications are restricted.

Specifications

B·NANO

Nano Handle for B·IRON

Ref.: **BN-A**

- Peak Power (Tool):	24 W
- Battery:	Li-Ion 7.4 V / 180 mAh
- Charge Time:	30 minutes
- Selectable Temperature:	100 - 450 °C / 210 - 840 °F
- Idle Temp. Stability (still air):	±1.5 °C / ±3 °F
- Temp. Accuracy:	±3% (Using reference cartridge)
- Connections:	Bluetooth Low Energy (BLE)
- Ambient Operating Temp:	10 - 50 °C / 50 - 122 °F
- Total Net Weight:	66 g / 0.15 lb
- Total Package Dimensions/Weight: (L x W x H)	220 x 75 x 30 mm / 110 g 8.66 x 2.95 x 1.18 in / 0.24 lb

Complies with CE standards.

Not grounded device. No ESD discharge feature.

JBC

Warranty

JBC's 2 year warranty covers this equipment against all manufacturing defects, including the replacement of defective parts and labour.

Warranty does not cover product wear or misuse.

In order for the warranty to be valid, equipment must be returned, postage paid, to the dealer where it was purchased.



This product should not be thrown in the garbage.

In accordance with the European directive 2012/19/EU, electronic equipment at the end of its life must be collected and returned to an authorized recycling facility.



www.jbctools.com

0033729-280524